

V-Shore Shoring System Safety Manual

Step 1

Place 4 base jacks on a flat ground within certain distance, Screw Jacks not to extend more than 600 mm.

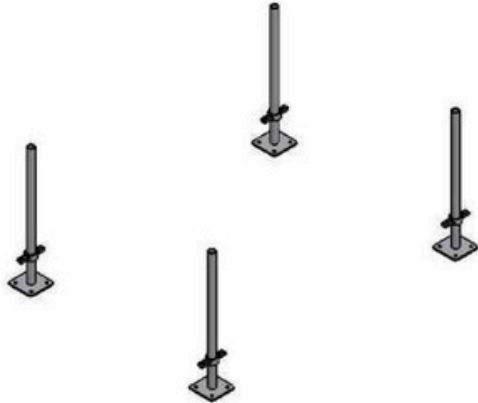

Step 2

Fit frames on the jacks, level the frames & connect the braces, lock all the safety pins after connecting the braces.



Step 3

Fit U-head jacks on top of the frames, eccentricity all parallel to frames, U-head jacks must not extend more than 600mm.

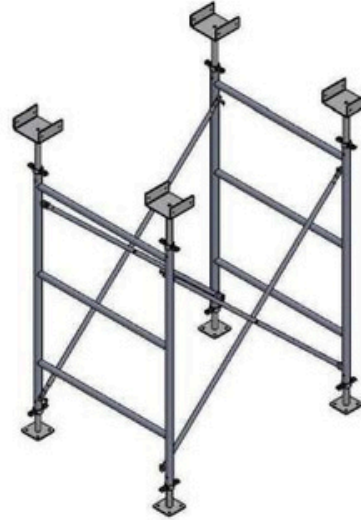

Step 4

Place beaming the U-head such that load is balanced over frame leg. Lap beams in U-head or turn U-head to ensure single beam is centrally located.

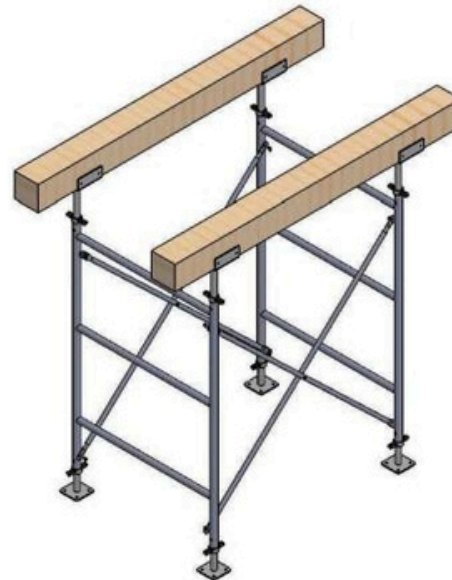

WARNING:

Do not apply eccentric loading on the U-head.

Do not offset the beam.

Prior to concrete pour, engineer must check that formwork and concrete loads must not exceed H-frame capacity (WLL), and visually inspect and sign off on correct erection of H-frame and formwork.

When adjusting the height of the U-head, only hit the handle, do not hit on the collar nut.

Nut adjustment must be less than 600mm.

2.1m V-frame

WLL:38KN/Leg

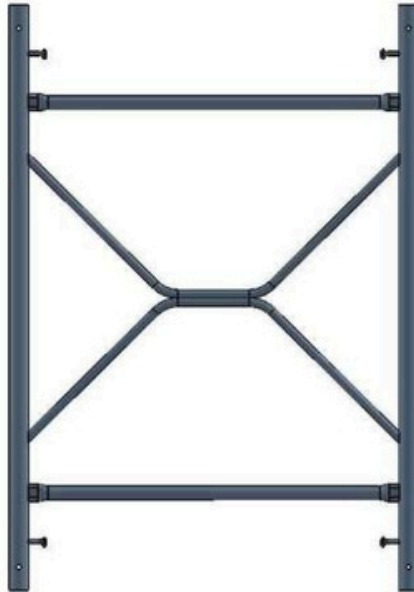

Name	Size
1.8m Frame	1829mm
2.1m Frame	2134mm

WARNING:

Do not use bent or damaged frame.

Brace

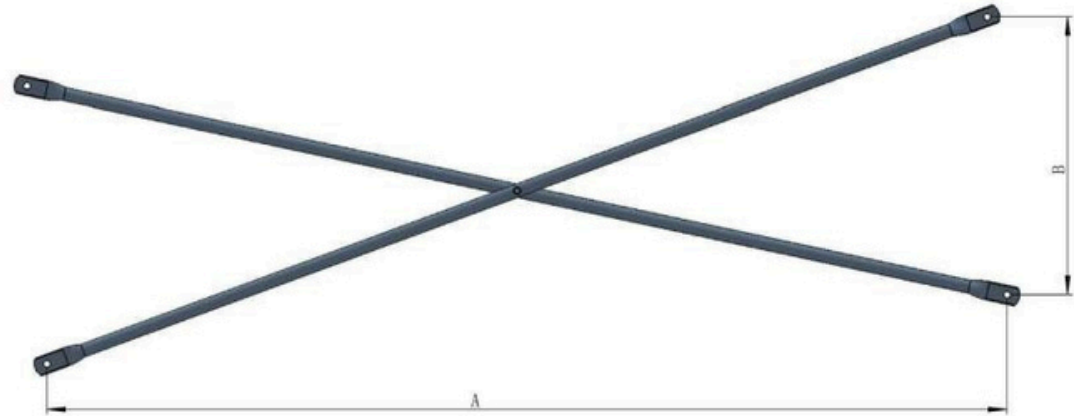

Span	Size				
A	1580mm	1530mm	1580mm	11530mm	1500mm
B	1524mm	1524mm	914mm	914mm	1214mm

Span	Size				
A	1200mm	1580mm	1200mm	1200mm	1200mm
B	1214mm	610mm	1524mm	914mm	610mm

WARNING:

Do not using broken or damaged brace,
only use the correct size braces to fit in the frames.

Check the nut is tight before using.

Base Jack & U Head Jack

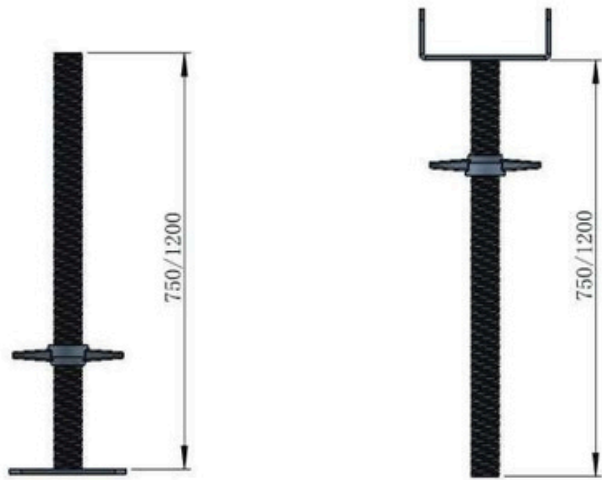

WARNING:

When adjusting the height of the U-head, only hit the handle, do not hit on the collar nut.

SAFETY USE:

Nut adjustment must be less than 600mm.

Connector & Locking Bolt

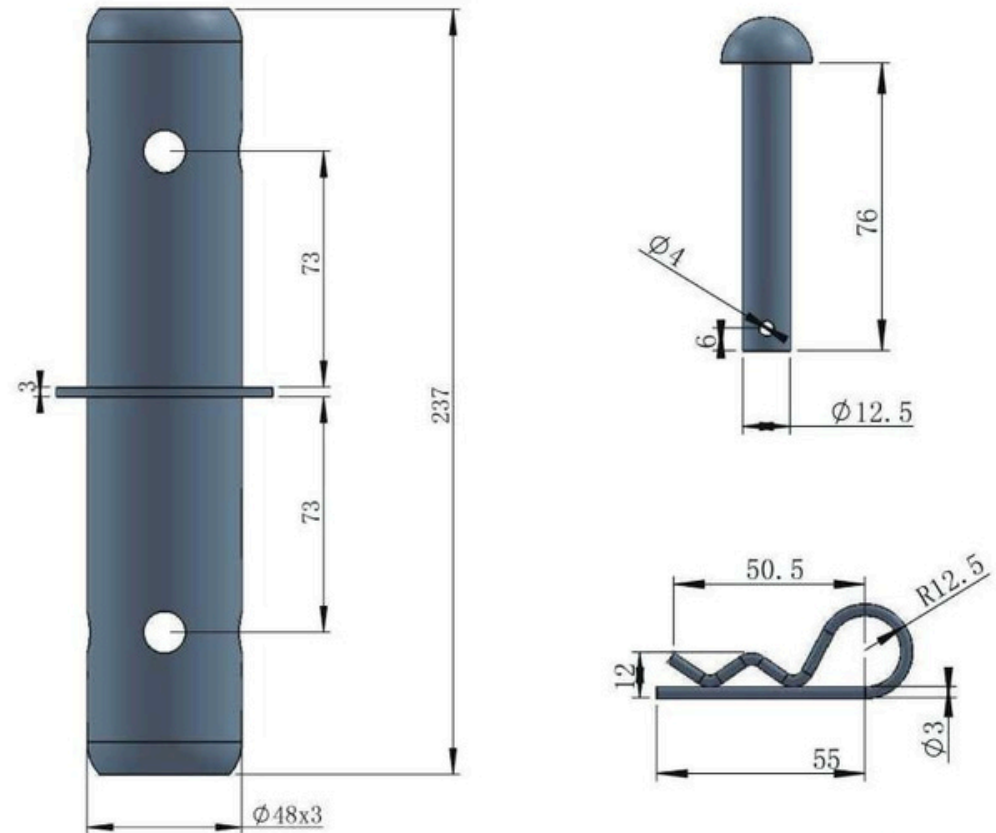

IMPORTANT INFORMATION

TRANSPORTING, STACKING AND STORAGE

1. Observe all regulations applying to the handling of formwork and scaffolding.
2. Remove any loose parts or fix them in place so that they cannot be dislodged or fall free.
3. Use AUSF stillage to safely stack & transport the gears.

INSTALLATION AND DISMANTLING

4. Always read this manual, product certificate or testing report before use.
5. The surface that supports the formwork frames must have sufficient strength to withstand:
 - The load of the frame;
 - The formwork;
 - Concrete poured on the formwork; and
 - Future work that will be done on the concrete surface.
6. Soils must be compacted to support these loads. Concrete surfaces from earlier work may require sole boards to prevent damage to the concrete surface or excessive concentration of loads beneath the base jacks.
7. Sole boards between the base plate and supporting surface must have adequate strength to support the load without undue settlement.
8. The LVL (or equivalent bearer) must extend the full length of two formwork shoring systems. A single bearer must be centered on the U-head. To ensure the bearer remains centered when it is narrower than the U-head, the U-head must be adjusted accordingly. Two bearers required to land on a single U-head must overlap to achieve full bearing on the U-head surface. Two bearers must not block or butt ends with each other.
9. Non-AUSF components must not be substituted for AUSF components. Violation of this policy will violate our terms & conditions, and invalidate the AUSF Safe Working Loads.
10. AUSF products must be used according to AUSF Technical specifications, industry-approved codes of practice, AS3610 and the OH&S Act. Usage of AUSF products must also comply with any additional regulations from statutory or regulatory bodies. Stacked frames must have engineering approval.

INSPECTION AND MAINTAINANCE

11. Routine inspection has to be carried out during or after the use of the equipment, make sure there is no damage and all components work properly.
12. Only original AUSF components may be used as spare parts.
13. Repairs may only be carried out by the manufacturer or authorized facilities.