



SCAFEAST 1.8M FORMWORK STANCHIONS SYSTEM **USER GUIDE**



SCAFEAST 1.8M FORMWORK STANCHIONS SYSTEM

Step One

1. Position the stanchion at live edge, install facing inside.

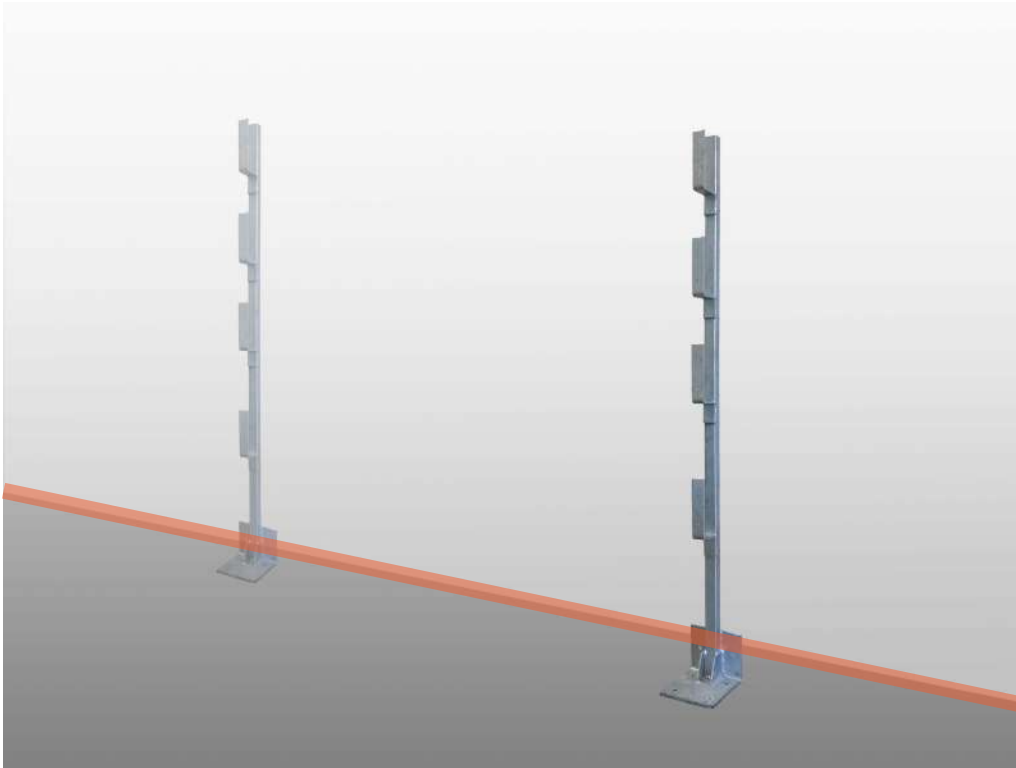

2. Ancor 4x ankascrews on the base into existing concrete structure.

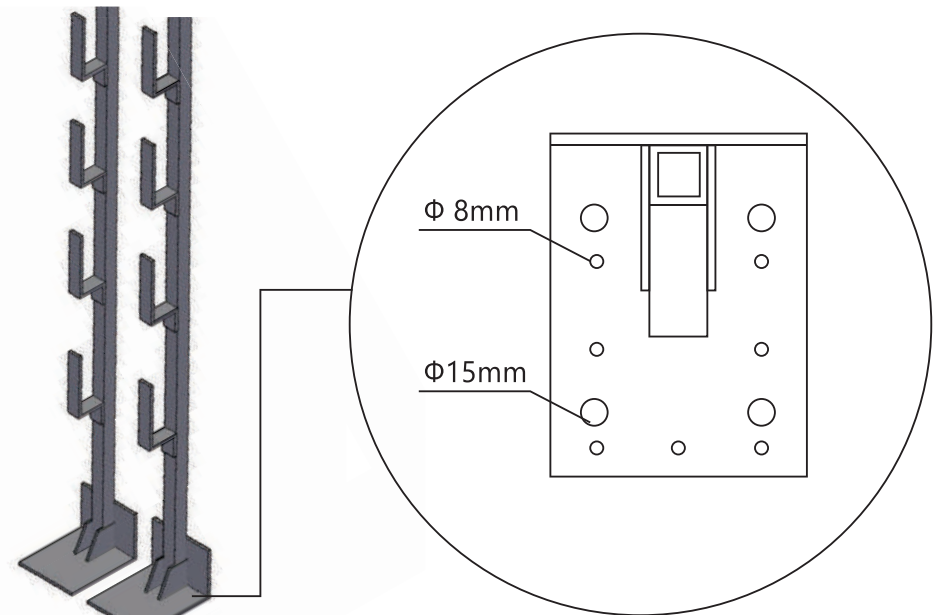

**ANKASCREW
AS121000
MIN 25MPa**

SCAFEAST

CUSTOMER QUALITY SUSTAINABILITY

SCAFEAST 1.8M FORMWORK STANCHIONS SYSTEM

Step Two

1.

Place the timber kickboard on the anchor points of the upright stanchion.

2.

Fasten the kickboard with Type 17 self drilling screws.
(positions as shown)

Toeboard minimum size: 38x225mm

Type 17 screw

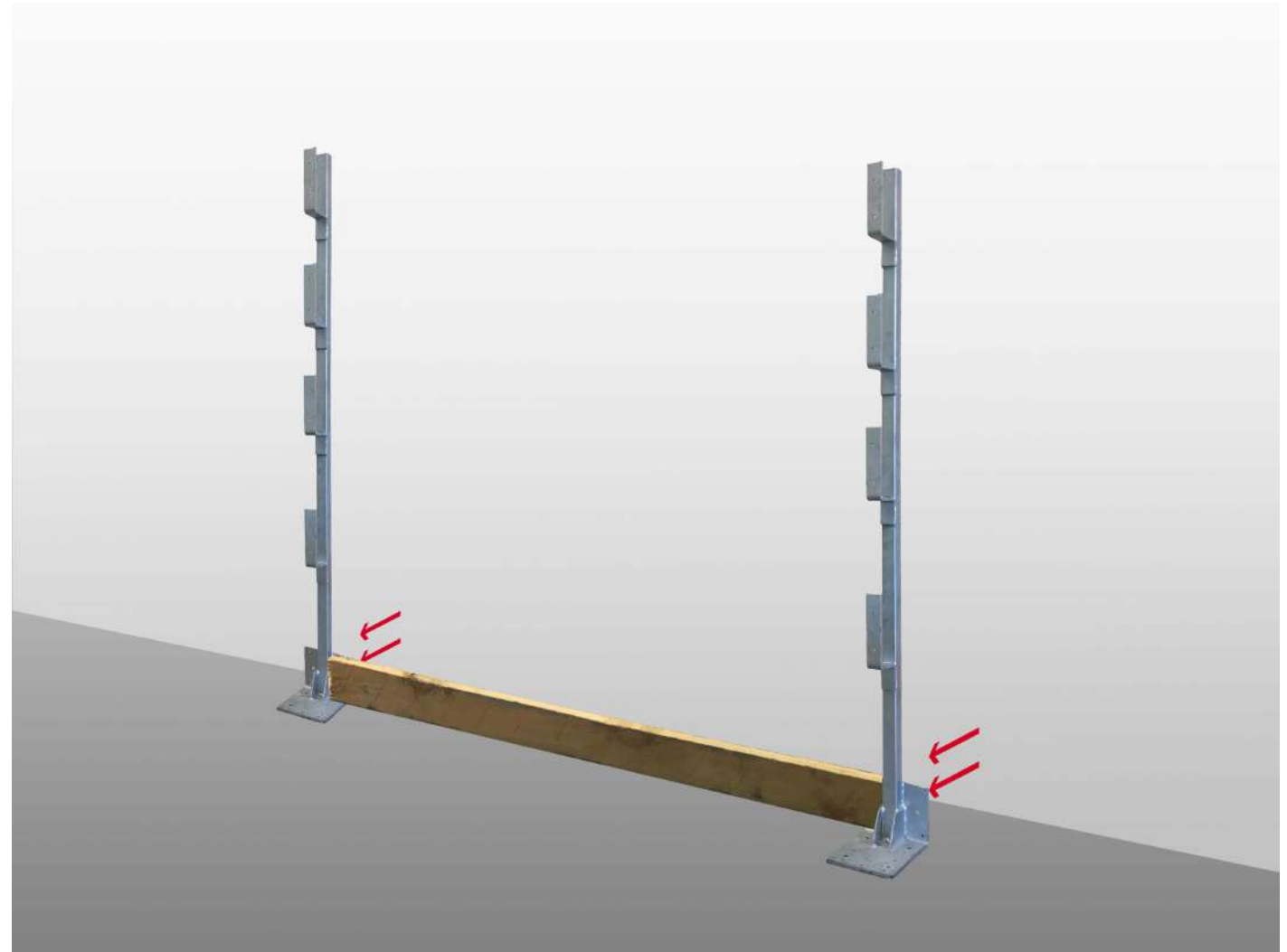
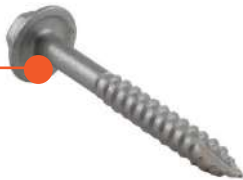

SCAFEAST 1.8M FORMWORK STANCHIONS SYSTEM

Step Three

1.

Place the next stanchion at a distance of up to 2.4 metres and anchor the base with screws.

2.

Fasten the kickboard to the second stanchion with screws.

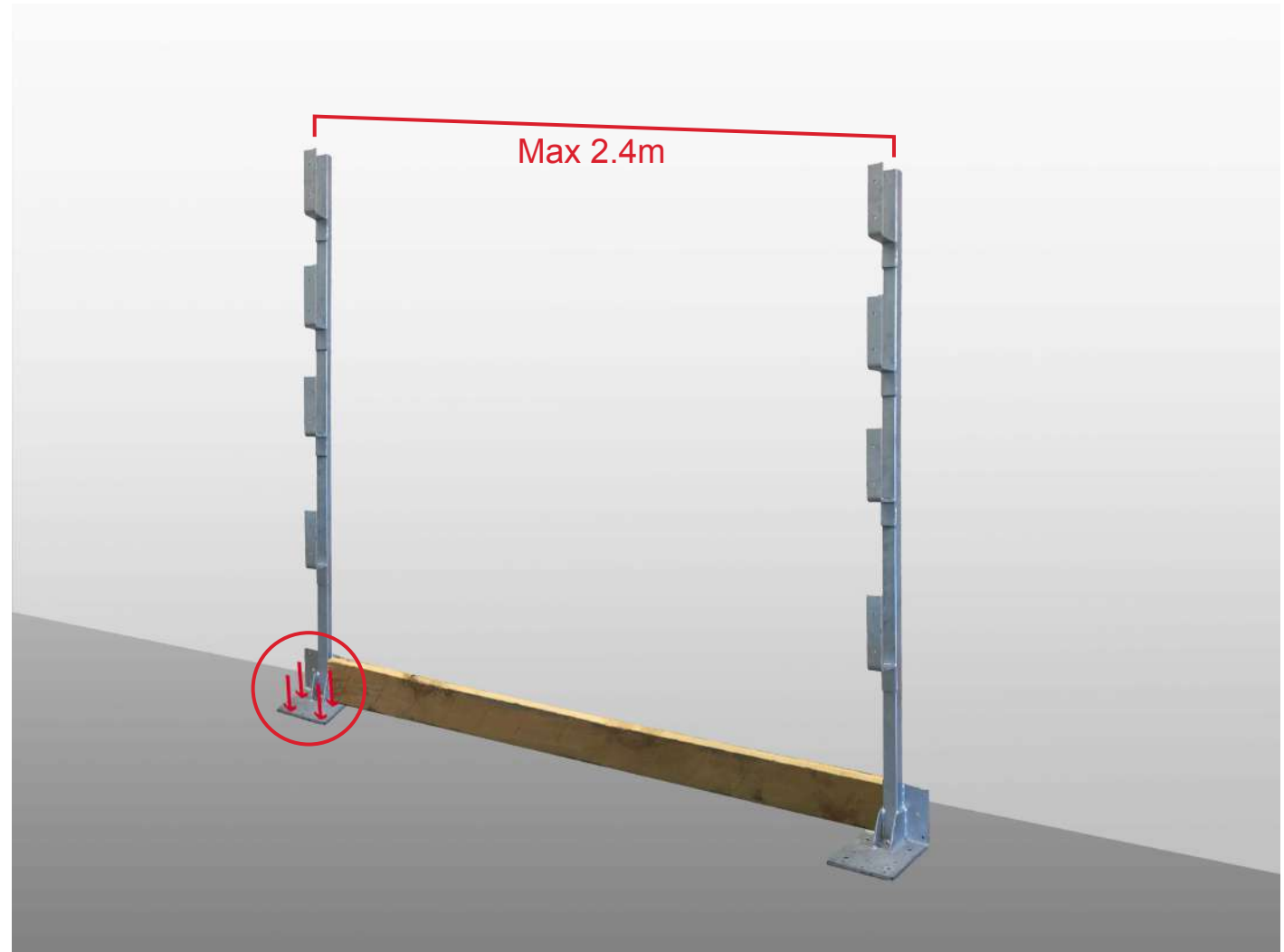

SCAFEAST 1.8M FORMWORK STANCHIONS SYSTEM

Step Four

Horizontal 4x guard bearers LVL 95x65, connect to the post by self-tapping screw bolt.

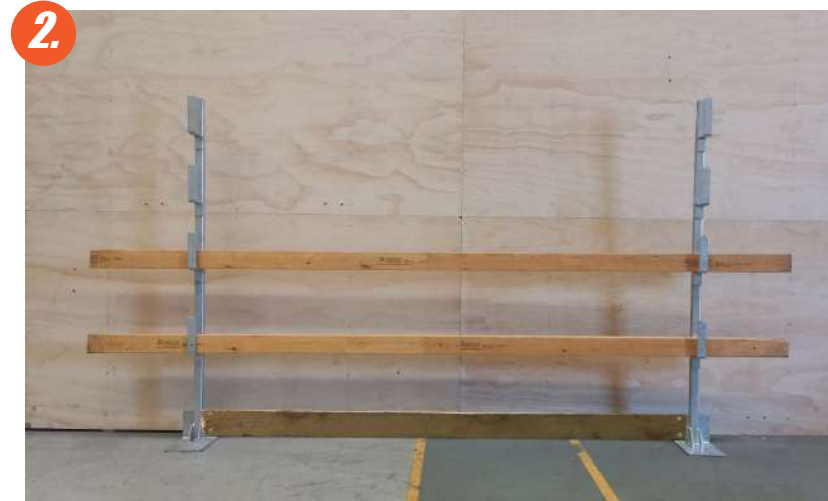

SCAFEAST 1.8M FORMWORK STANCHIONS SYSTEM

Regulation

1.

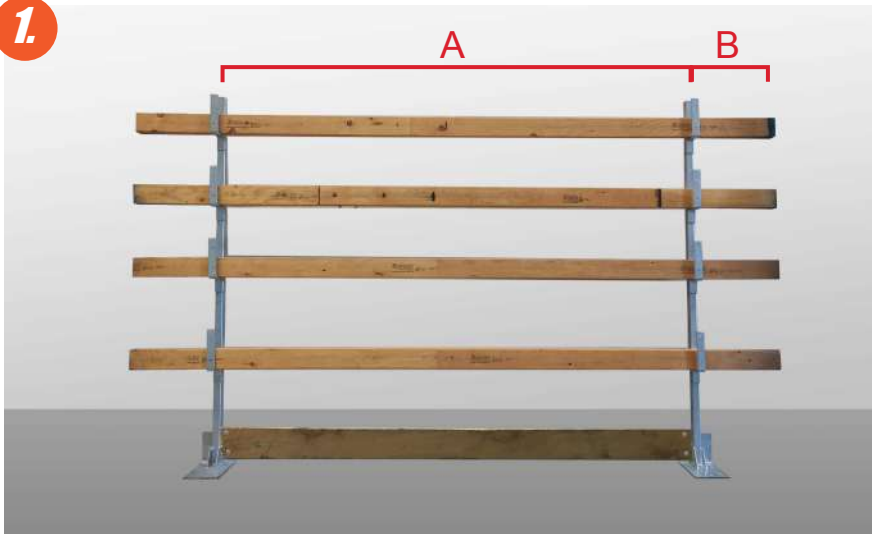

A
Maximum distance between two stanchions:
2400mm

B
Maximum over hang of I/I rail each side:
300mm

2.



How to position stanchions in corners?

Scafeast stanchion system have been designed for all scenarios, please see the picture provided to shown how you position the stanchions on angle.



SCAFEAST 1.8M FORMWORK STANCHIONS SYSTEM

Regulation

TRANSPORTING, STACKING AND STORING

1. Observe all regulations applying to the handling of formwork and scaffolding.
2. Remove any loose parts or fix them in place so that they cannot be dislodged or fall free.
3. Use SCAFEAST stillage to safely stack & transport the stanchions.

INSPECTION AND MAINTAINCE

1. Routine inspection has to be carried out during or after the use of the equipment, make sure this is no damage and all components works properly.
2. Only original SCAFEAST components may be used as spare parts.
3. Repairs may only be carried out by the manufacturer or authorized facilities.

We reserve the right to make alterations in the interests of technical progress.



DANDENONG SOUTH
13B Monterey Road,
Dandenong South, VIC 3175
1300 622 686

LAVERTON NORTH
119 Pipe Road,
Laverton North, VIC, 3175
(03) 9317 3864

VILLAWOOD NSW
1/264 Miller Road,
Villawood, NSW, 2163
(02) 8747 1851